

we reduce it. waste. costs. problems.

# VEGA. Single-Shaft Shredder.

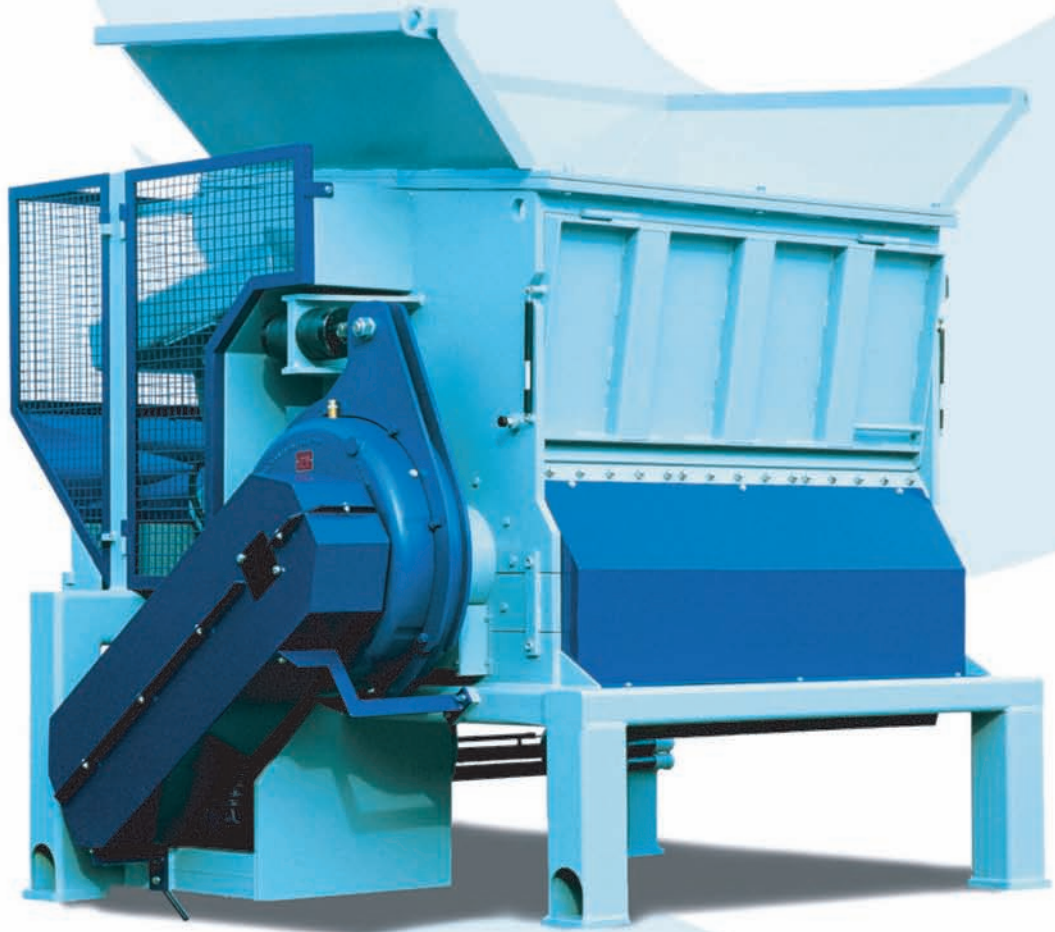

PO Box 6010 East Brighton  
Victoria 3187 Australia  
p + 61 3 9592 4304  
f + 61 3 9591 0581  
e info@koga.com.au  
w www.koga.com.au

# VEGA.

## 1500

### Product description

Cost-effective single-shaft shredder for processing a wide range of waste materials for smaller requirements.

### Throughput capacity

e.g. with loose plastic film and screen size 50 mm: 1 t/hour.

### Material specification

Mixed plastics for thermal utilisation and recycling; paper, cardboard, files; plastic and foam materials, containers, rubbers, leather, textiles, floor coverings, cables, computer scrap, wood, etc.



The milling rotor permits low-vibration running by means of its special blade arrangement. The Monofix system ensures rapid blade change.

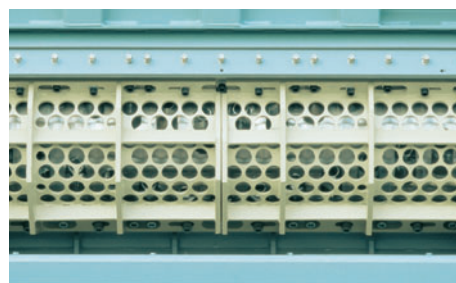

The rapidly changeable screen with a diameter of 11 to 80 mm supplies defined grain size.

### Technical data

	VEGA 1500
Feed opening	2200 x 1500 mm
Hopper space	app. 2 m <sup>3</sup>
Shredding area	1100 x 1500 mm
Rotor periphery	1500 mm
Rotor circle	434 mm
Rotor speed	80 rpm
Number of blades	52
Number of counter blades	3
Number of scrapers	3
Drive rating	55 kW
Hydraulic pusher system	5,5 kW
Screen	11 - 80 mm
Weight	ca. 7.000 kg

Technical subject to alteration.

### Principal sections

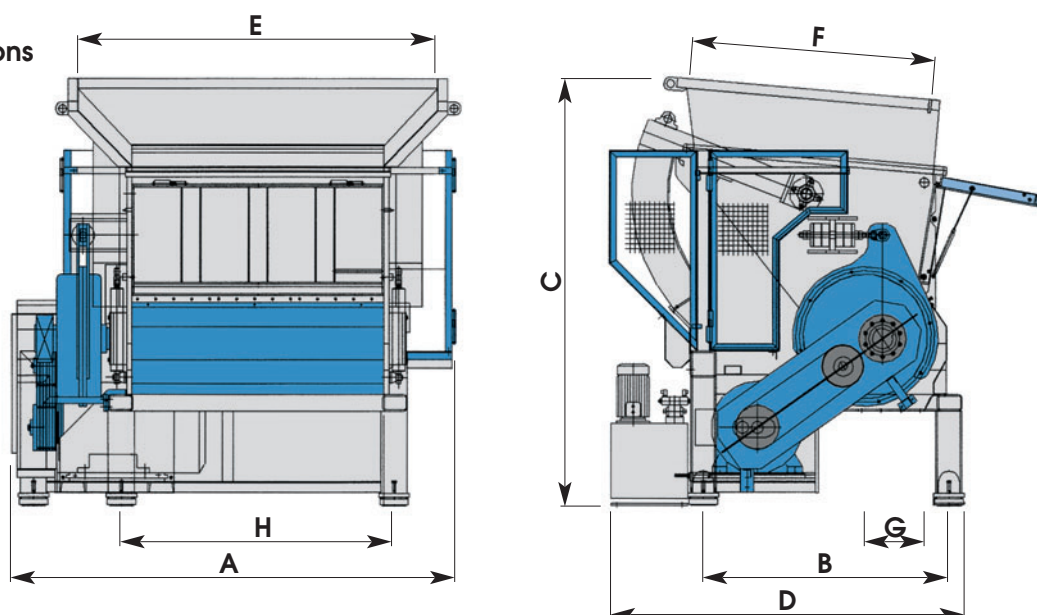

### Dimensions

in mm	A	B	C	D	E	F	G	H
VEGA 1500	2700	1500	2610	2170	2200	1540	400	1670

vers. 04\_2006

size reduction machines and systems