

we reduce it. waste. costs. problems.

ORION. Twin-Shaft Rotary Shears.



PO Box 6010 East Brighton
Victoria 3187 Australia
p + 61 3 9592 4304
f + 61 3 9591 0581
e info@koga.com.au
w www.koga.com.au

ORION.

850-1200-1500

Product description

Slow running twin-shaft rotary shears with exchangeable cutting discs for the primary size reduction of diverse waste materials.

System advantage

- Min. operating noise through slow-running cutting mechanism
- Energy-saving through low connection load
- Reliable, fully automatic operation through electronic monitoring/control and overload protection
- Cutting blades made of hardened tool steel guarantee unmatched long service life
- All parts of the cutting mechanism are produced on ultra-modern CNC precision machinery
- Cutting system can be exchanged without difficulty by means of polygon-shaft-hub connection

Throughput capacity

e.g. plastic and steel containers (30 - 1000 litres) app.
1,5 - 30m³/hour

Material specification

Large volume hollow containers, pallets, crates, waste wood, plastics, foams, insulation materials, rubber, styrofoam, plastic and metal barrels, textiles, car tires, bumpers, cartons, fridges, waste from chemical industry, etc.

Technical data

	ORION 850	ORION 1200	ORION 1500
Feed opening	1500 x 1000 mm	1800 x 1000 mm	2050 x 1350 mm
Hopper space	app. 0,6 m ³	app. 1,8 m ³	app. 3 m ³
Shredding area	850 x 700 mm	1230 x 1050 mm	1400 x 1100 mm
Number of blades	37 or 21	28 or 14	28 or 14
Blade width	20 or 40 mm	40 or 90 mm	50 or 100 mm
Cutting disc dia.	345 mm	394 mm	496 mm
Drive power	2 x 11 kW, 2 x 18,5 kW, 2 x 22 kW	2 x 15 kW, 2 x 18,5 kW, 2 x 22 kW	2 x 55 kW
Weight	app. 4.000 kg	app. 8.000 kg	app. 14.500 kg

Technical subject to alteration.

Principal sections

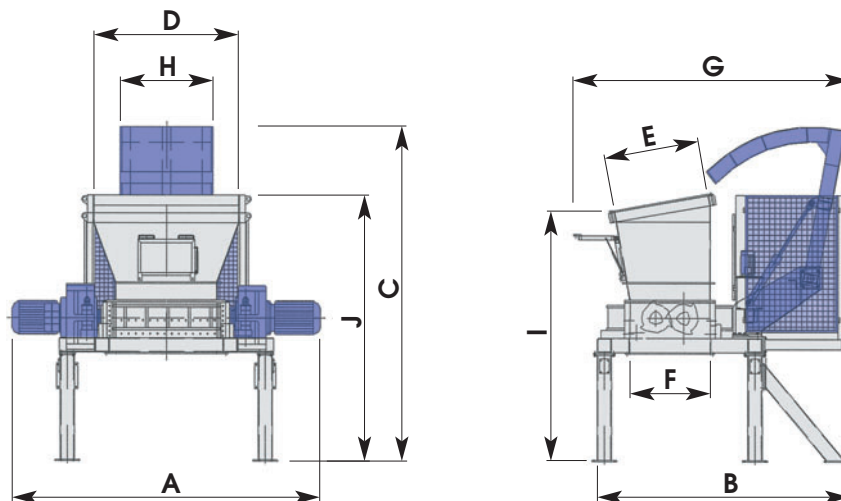

Dimensions

in mm	A	B	C	D	E	F	G	H	I	J
ORION 850	3170	2430	3480	1500	1000	700	2430	750	2900	3030
ORION 1200	3800	3000	4200	1800	1200	1050	3000	1100	2980	3030
ORION 1500	4350	3620	4670	2050	1350	1100	3880	1300	3500	3700

vers. 04_2006

size reduction machines and systems



Machined cutting blade edges made of high-alloy tool steel prevent a reduction in the material structure. The polygon-shaft-hub connection ensures maximum torque transmission and easy changing of the cutting discs.